



KABA®

Product facts
HSD Swing Doors
PGB Personal Guiding Bars
CRP Reader Posts

Swing Doors HSD

Basic equipment

HSD-E01

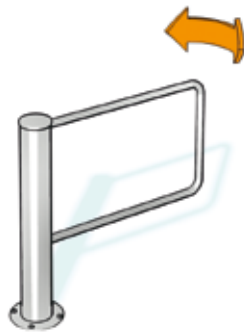

Construction	tubular column	made of stainless steel AISI 304, Ø 140
	barrier element	curved, Ø 40, made of stainless steel tube AISI 304
	door wing radius	900
	top edge of door wing	900
		locking system, drive and toothed holding brake installed in tubular column
Finish		stainless steel satin finish
Function		type 2*
		both in entry and exit direction 90° opening
Electrical components		control system and power supply in an external switch cabinet H = 320 / W = 175 / D = 90
		power supply 110-230 VAC, 50/60 Hz
Installation		dowelled on finished floor level FFL suitable for outdoor installation

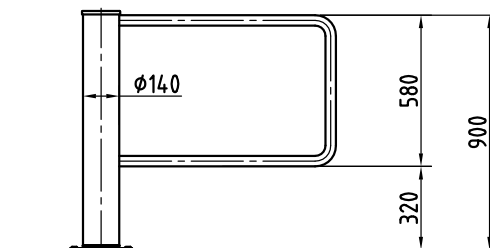

* Type 2: power assisted motion;
servo-positioning drive/
electrically controlled
in both directions

All dimensions in mm

HSD-E03

Option

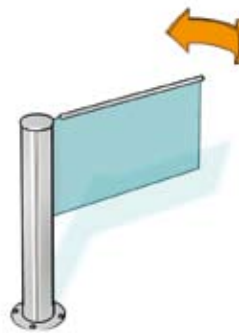
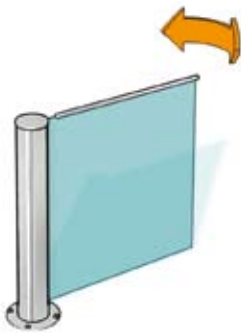

made of stainless steel AISI 304, \varnothing 140
high element made of 10 mm toughened glass,
with bar handle

900

900

locking system, drive and toothed holding brake
installed in tubular column

stainless steel satin finish

type 2*

both in entry and exit direction

90° opening

control system and power supply in an external switch cabinet

H = 320 / W = 175 / D = 90

power supply 110-230 VAC, 50/60 Hz

dowelled on finished floor level FFL

not suitable for outdoor installation!

HSD-E03 with option
"half-height barrier element"

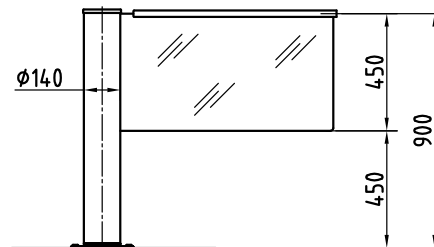
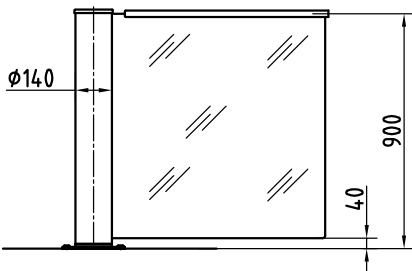

Swing Door HSD

Option

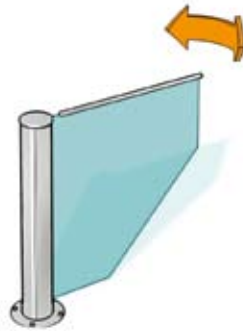

Construction	tubular column barrier element
	door wing radius top edge of door wing
Finish	
Function	HSD-E03 with option "bevelled barrier element"
Electrical components	
Installation	

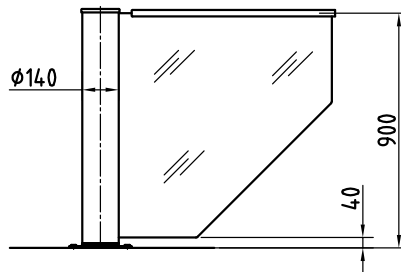

* Type 2: power assisted motion;
servo-positioning drive/
electrically controlled
in both directions

All dimensions in mm

Options for Swing Doors HSD

	HSD-E01	HSD-E03
Construction		
• bevelled barrier element		•
• half-height barrier element		•
• passage width 1000 mm	•	•
• passage width: minimum 650 mm, max. 1200 mm, max. 999 mm with HSD-E03	•	•
• glass pane of door wing in toughened glass (sealed at top and bottom)	•	
• special height: extension of door wing to top edge of 1200 mm	•	•
Function		
• master for linkage of 2 units as double swing door	•	•
• emergency and rescue module	•	•
• additional emergency push-button including symbol for connection to emergency and rescue module	•	•
Electrical components		
• power supply plug 24VDC/1A to supply external nodes	•	•
• operating panels with frame or housing for surface installation	•	•
• additional I/O boards to expand the existing in- and outputs	•	•
• end wiring distributor to connect a maximum of four OPLs	•	•
Installation		
• trapezoid plate with variable substructure, measue X= 80 - 180 mm	•	•
• cast-in floor element	•	•

Installation variations for swing door HSD

dowelled on finished floor level FFL (standard)

by trapezoid plate on structural floor level SFL

cast-in finished floor level FFL

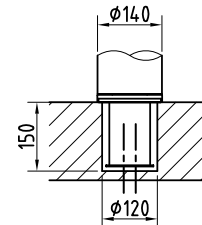
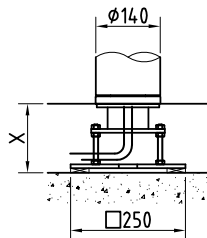
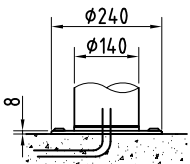

All dimensions in mm

Personal Guiding Bars PGB

Basic equipment

PGB-E01



PGB-E02



Construction	description	pedestrian guiding element made of tubular stainless steel AISI 304 satin finish Ø 40 mm	pedestrian guiding element with crossbar, height 320 mm, made of tubular stainless steel AISI 304 satin finish Ø 40 mm
	total height	900	900
	axial dimension	870	870
Finish		stainless steel satin finish	stainless steel satin finish
Installation		on finished floor level FFL with flange plate Ø 140, suitable for outdoor installation	on finished floor level FFL with flange plate Ø 140, suitable for outdoor installation

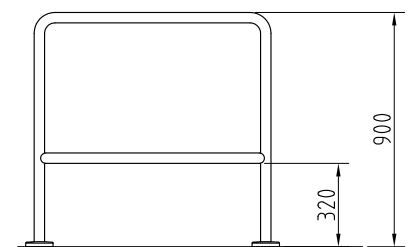
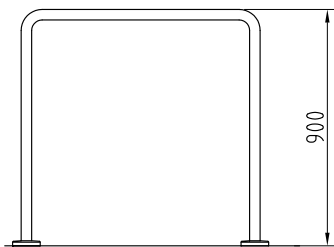

All dimensions in mm

PGB-E03



pedestrian guiding element with crossbar, height 320 mm,
made of tubular stainless steel AISI 304 satin finish
Ø 40 mm with toughened glass panel 6 mm

900

870

stainless steel satin finish

on finished floor level FFL with flange plate Ø 140,

suitable for outdoor installation

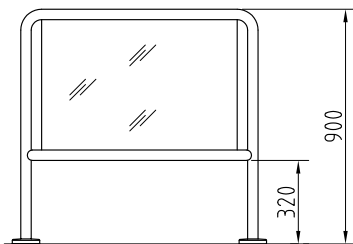

Personal Guiding Bars PGB

Basic equipment

PGB-S01



Construction	description	pedestrian guiding element as variable full-glass barrier system with two stainless steel posts AISI 304 satin finish \varnothing 48 mm and toughened glass 10 mm (visible edges grinded and polished)
	total height	900
	axial dimension	870
Finish		stainless steel satin finish
Installation		on finished floor level FFL with flange plate \varnothing 140, suitable for outdoor installation

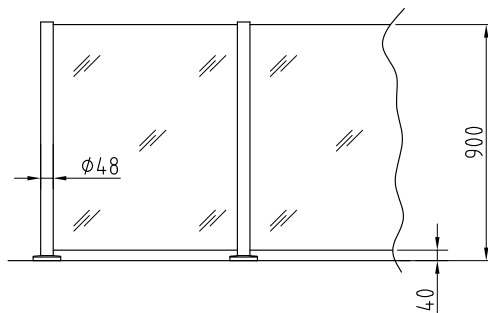

All dimensions in mm

Options for Personal Guiding Bars PGB

Construction

- measure of axis shortened (500 - 870 mm) or extended
- middle post for measure of axis >1500 mm

Installation

- cast-in into on-site tapping drill hole, including stainless steel rosettes and grouting mortar
- clamp fixing cast-in into on-site tapping drill hole, including stainless steel rosettes and grouting mortar
- installation plugable including fixing material and stainless steel rosettes
- dowelled on structural floor level SFL, including stainless steel rosettes
- trapezoid plate with variable substructure, measue X= 80 - 180 mm, including stainless steel rosettes

	PGB-E01	PGB-E02	PGB-E03	PGB-S01
• measure of axis shortened (500 - 870 mm) or extended	•	•	•	•
• middle post for measure of axis >1500 mm	•	•	•	•
• cast-in into on-site tapping drill hole, including stainless steel rosettes and grouting mortar	•	•	•	•
• clamp fixing cast-in into on-site tapping drill hole, including stainless steel rosettes and grouting mortar	•	•	•	•
• installation plugable including fixing material and stainless steel rosettes	•	•	•	•
• dowelled on structural floor level SFL, including stainless steel rosettes	•	•	•	•
• trapezoid plate with variable substructure, measue X= 80 - 180 mm, including stainless steel rosettes	•	•	•	•

Installation variations for Personal Guiding Bars PGB

dowelled on finished floor level FFL (standard)

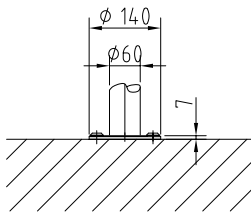

cast-in finished floor level FFL

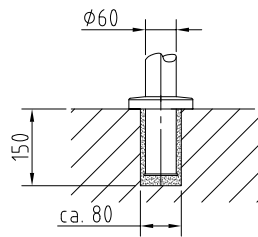

clamp fixing in finished floor level FFL

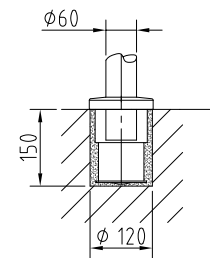

trapezoid plate with variable substructure on structural floor level SFL

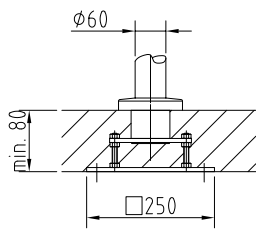

dowelled on structural floor level SFL

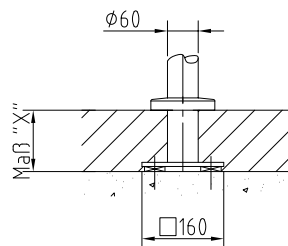

plugable into finished floor level FFL

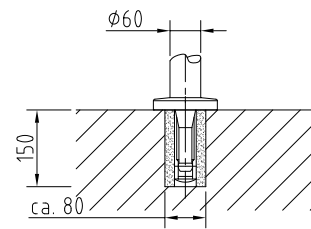

All dimensions in mm

Reader Posts CRP

Basic equipment

CRP-E01



CRP-E03



Construction	description	CRP-E01	CRP-E03
		reader post made of stainless steel tube AISI 304 with aluminium distance piece 80 x 35 mm lacquered in RAL 9006, with cable bore for customer's reader plate (surface-mounted)	column made of stainless steel AISI 304 with removable maintenance opening to install devices supplied by customer (maximal dimensions H = 170 mm / W = 140 mm / D = 150 mm).
	height	1100	1250
	width	-	205
	depth	-	160
	diameter	48 optional 60	-
Finish		stainless steel satin finish	stainless steel satin finish
Application		designed for small card reader, installed on-site	particularly suitable for different reader measurements or several different built-in components
Electrical components		-	-
Installation		on finished floor level FFL suitable for outdoor installation	on finished floor level FFL suitable for outdoor installation

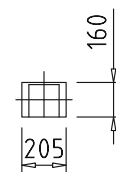
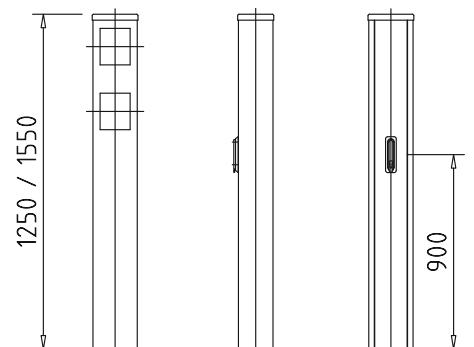
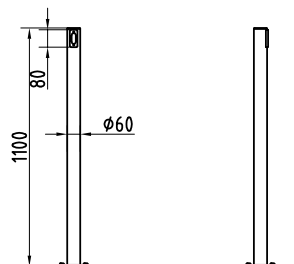

CRP-C01



card reader post made of stainless steel tube AISI 304 with bevelled head (30°).
Installation of devices has to be checked in individual cases

1100

-

-

206 optional 256

stainless steel satin finish

attractive variant in appealing design, suitable for small card reader and signal devices

-

on finished floor level FFL

suitable for outdoor installation

CRP-C02



Card reader post made of stainless steel tube AISI 304. Vertical installation of devices, which has to be checked in individual cases

1100

-

-

206 optional 256

stainless steel satin finish

stylish card reader post for large-size card reader

-

on finished floor level FFL

suitable for outdoor installation

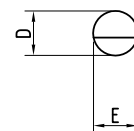
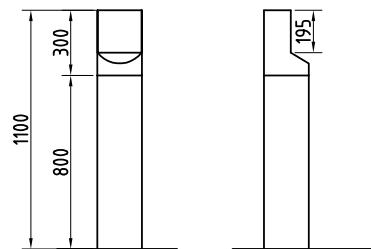
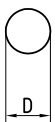
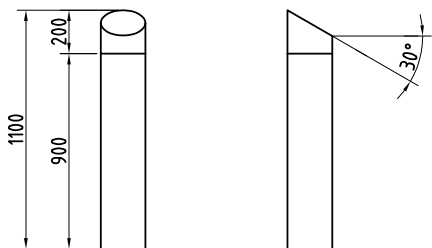

Reader Posts CRP

Basic equipment

CRP-M01



CRP-M02



Construction	description	CRP-M01	CRP-M02
		card reader post made of stainless steel tube AISI 304 to check and collect identification cards together with the badge holder and clip (length 90 mm / width 63 mm / thickness 5 mm). Included tray for returning cards, signal display (red / green) in the top horizontal cover, card slot with automatic closing function and lockable collecting box. Presence identification for nonreadable cards	card reader post made of stainless steel plate AISI 304 to check and collect identification cards together with the badge holder and clip (length 90 mm / width 63 mm / thickness 5 mm). With protective cover for outdoor installations as well as included tray for returning cards, signal display (red / green) in the bevelled cover, card slot with automatic closing function and lockable collecting box. Presence identification for nonreadable cards
	height	1180	1094
	width	-	260
	depth	-	160
	diameter	140	-
Finish		stainless steel satin finish	stainless steel satin finish
Application		prepared to install a Legic®-Antenne LA-PP and a KABA DML 2 control. Adaptation to other reader systems on request	prepared to install a Legic®-Antenne LA-PP and a KABA DML 2 control. Adaptation to other reader systems on request
Electrical components		power supply 24 VDC	power supply 24 VDC
Installation		on finished floor level FFL not suitable for outdoor installation!	on finished floor level FFL suitable for outdoor installation

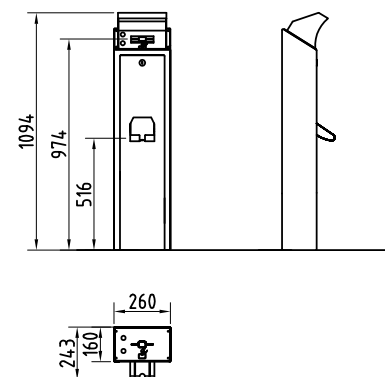
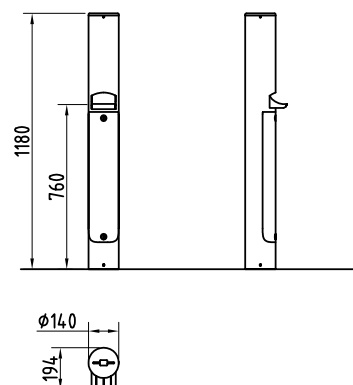

All dimensions in mm

CRP-M03



card reader post made of stainless steel plate AISI 304 to check and collect identification cards together with the badge holder and clip (length 90 mm / width 63 mm / thickness 5 mm). Included tray for returning cards, all-over signal display (red / green) in the bevelled cover and lockable collecting box.

Presence identification for nonreadable cards

2550

350

250

-

stainless steel satin finish

prepared to install a Legic®-Antenne LA-PP and a KABA DML 2 control.

Adaptation to other reader systems on request

power supply 24 VDC

on finished floor level FFL

suitable for outdoor installation

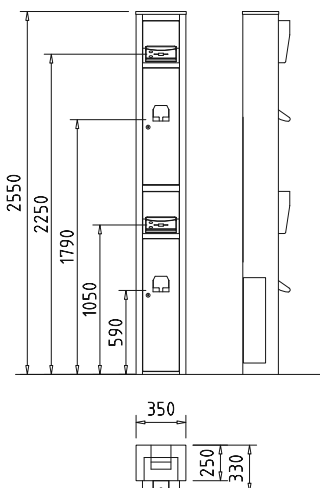

Options for Reader Posts CRP

	CRP-E01	CRP-E03	CRP-C01	CRP-C02	CRP-M01	CRP-M02	CRP-M03
Electrical components							
• installation preparation on flat surface, rectangular cut-out for readers provided by customer		•	•	•			
• cover plate with flush box for installation of components provided by customer			•				
• reader console instead of aluminium distance piece: milled plate in aluminium, lacquered in RAL 9006, measures aligned to components supplied by customer	•						
• Legic-Antenna LA-PP and control KABA DML 2: Installation of componenets supplied by customer or components provided by Kaba					•	•	•
Installation							
• trapezoid plate with variable substructure, measue X= 80 - 180 mm	•	•	•	•	•	•	•
• clamp fixing cast-in into on-site tapping drill hole	•						

Installation variations for Reader Posts CRP

trapezoid plate

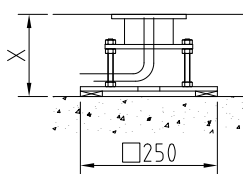

clamp fixing cast-in

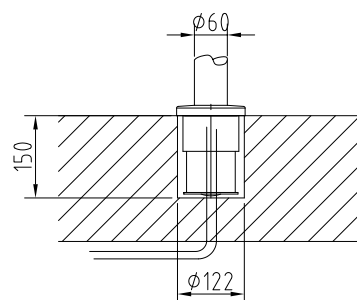

All dimensions in mm

The logo for KABA, featuring the word "KABA" in a bold, stylized, blue font with a registered trademark symbol (®) to the right. The letters are blocky and interconnected, with the 'A' having a unique shape. The logo is set against a white rectangular background.

Kaba Gallenschütz GmbH
Nikolaus-Otto-Strasse 1
77815 Bühl
Germany
Tel. +49 (0) 7223/286-0
Fax +49 (0) 7223/286-111
info@kgb.kaba.com

www.kaba-gallenschuetz.de